

THE XTREMA IS A COMPACT, COMPLETELY HYDRAULIC CONTROLLED HIGH DUMP SWEEPER DESIGNED AND MANUFACTURED BY EUREKA TO SWEEP CONGESTED AREAS AS WELL AS LARGE FLOOR SPACES. IT HAS A MAIN BRUSH WIDTH OF 800 MM, A TOTAL SWEEPING PATH OF 1400 MM AND A CLEANING CAPACITY, AT FULL SPEED, OF 12.600 SQ/M²H.

Hydraulically driven traction, container lift, brushes and vacuum fan, enable the Xtrema clean the dirtiest floors very rapidly, and keep routine maintenance very simple thus reducing downtime.

MANOEUVRABILITY EFFICIENCY

The compactness of this sweeper, with its small turning radius (1.600 mm) makes it particularly suitable for sweeping in narrow, confined areas not accessible by larger machines, yet at a speed and productivity of much bigger sweepers.

POWER EFFICIENCY

The hydraulic drive on the front wheel enables the Xtrema to climb 20% gradients. The powerful Kubota engine grants world-wide assistance. More horsepower, twin cylinder, and liquid cooled system allows for overall better performances, and longer lasting life.

WASTE COLLECTION EFFICIENCY

To enable the main brush to work on most floor types, we have designed an exclusive 3 section, integrated bristle brush. The main brush floats for better performances on uneven floors, and automatically adjusts itself

VALUE ADDED FEATURES

- REAR MULTI-LEVEL-DUMP HOPPER
- NO TOOLS BRUSH CHANGE
- RETRACTABLE SIDE BRUSH
- REMOVABLE SIDE PANELS
- STEEL BUMPER
- POLYESTER BAG FILTER, CLASS USG
- ELECTRIC FILTER-SHAKER
- HEAD LIGHTS
- VACUUM PRE-FILTER ON AIR INTAKE
- FULL RUBBER, NON-MARKING TYRES

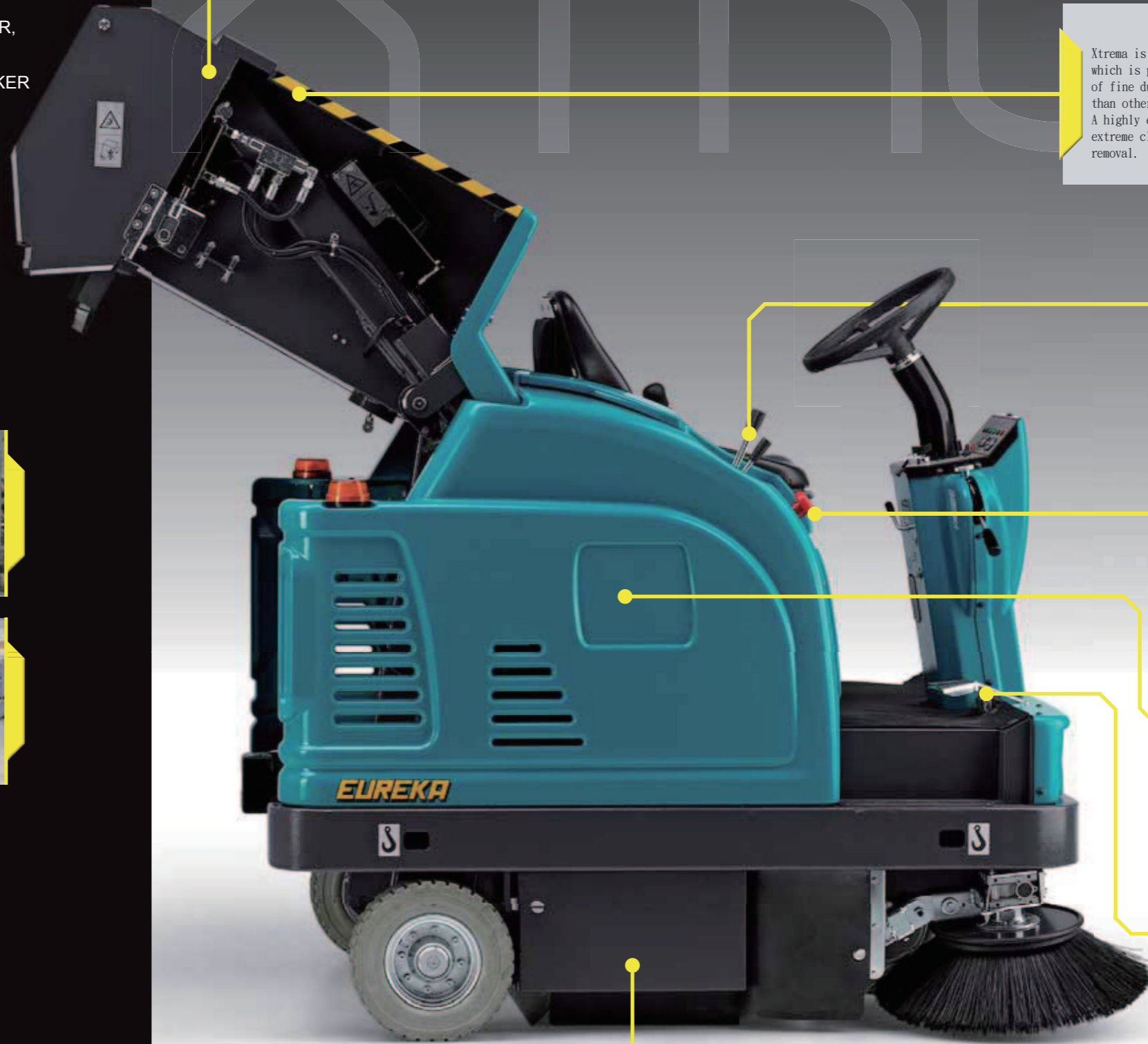

The multi-level-dump hopper, equipped with hydraulic flap, is located in the rear of the machine, can be hydraulically raised up to 1360 mm from the floor, and has a volume capacity of 150 litres.



Xtrema is equipped with a polyester bag filter which is particularly efficient for the retention of fine dust, and has a much longer lasting life than other traditional filters. A highly efficient dust filter-shaker provides extreme cleaning without the need for filter removal.



The brush pressure on the floor can be adjusted while working. This is done thanks to an exclusive, precise control positioned on the dashboard



Easy to use controls enable the operator to focus on sweeping to get the job done rapidly and efficiently



Xtrema is also available battery powered, which is particularly recommended for the sweeping of indoor areas.

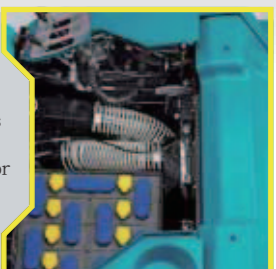

Strong hydraulic drive system, variable speed controlled up to 8,5 Km/h, by means of two pedals (fwd & rev)



The main brush can be rapidly replaced without tools. The dust filter can be replaced in a few seconds. All parts, motors, engines etc. are easily accessible for servicing, as side, upper and rear panels can be totally opened.



XTREMA



VALUE ADDED OPTIONS

- Complete head/tail lights package
- Audio/visual back-up alarms
- Overhead guard
- PVC windscreen
- Left side brush kit
- Automatic filter-shaking system
- Flashing lights (standard in UE countries)
- Class M filter

AVAILABLE VERSIONS

XTREMA DK with liquid cooled, twin cylinder diesel engine
 XTREMA EB battery powered, 24V

FIELDS OF APPLICATION:

industrial sites, communities and vicinities, schools, offices, religious buildings, hospitals, public buildings, airports, ports, shopping malls, logistical depots, cleaning companies, and multi services.

SUITABLE CLEANING SURFACES:

ceramics, marble, cement/concrete, linoleum, non-slip surfaces, porcelain tiling, and many other dirty conditions...

TECHNICAL SPECIFICATIONS	XTREMA EB	XTREMA DK
Sweeping path with side brushes	1400 mm	1400 mm
Sweeping path only main brush	800 mm	800 mm
Capacity of dirt container	150 Kg	150 Kg
Dumping height, hydraulic lift	1.360 mm	1.360 mm
Forward speed	8,00 km /h	9,00 km /h
Cleaning capacity	11.200 sq/m /h	12.600 sq/m /h
Filter type	polyester bag	polyester bag
Drive	electronic assisted	hydraulic
Drive motor	24V - 900W	hydraulic
Main motor	1 x 24V - 2000W	Kubota 14 Hp
Battery system	1 x 24V	-
Weight with battery	920 kg	785 kg
Size with brushes	1400 x 1695 x 1480 h	1400 x 1695 x 1480 h



AUTHORIZED DEALER



SWEEPERS LINE



XTREMA A BRAND NEW KIND OF SWEEPING POWER



JNT 權能國際股份有限公司
 新北市三重區興德路86號4樓(遠見科技大樓)

電話: 02-29957337(代表) 傳真: 02-29957031
 www.joynice.com.tw
 inf@joynice.com.tw



www.facebook.com/eurekasweepers
 www.youtube.com/eurekasweepers

